

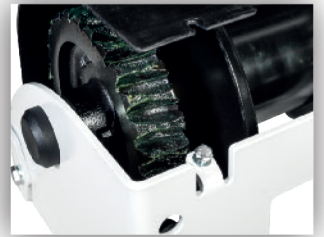

WW250-500-1000-1500 ../2D



Worm gear winch

Hand operated worm gear winch:

- robust and safe hoisting winch
- suitable for two cables
- in compliance with EN13157, DIN 15020 and EX types ATEX 114 (94/9/EG)
- static safety factor 4
- square worm-wormwheel transmission and maintenance free bearings
- cable outlet upwards, downwards or at rear
- adjustable crank, with ergonomic grip
- easy to grease worm-wormwheel transmission
- load pressure brake with silent double ratchet system
- paint thickness is 60 - 80 Micron in 1 layer (in compliance with DIN/ISO 12944, C1M)
- as option:
 - zinc-plated finish (6 - 8 Micron)
 - ATEX certified  II 3 GD T4, suitable for zone 2 and 22
 - grooved drum
 - crank force limiter
 - multiple compartment cable drum
 - WW1000 and WW1500 are suitable for winch power tool AM5000



WINCH SYSTEMS

Telephone: +44 (0)1482 620991
Email: sales@winchsystems.co.uk
Web: www.winchsystems.co.uk

GEBUWIN
metal products

Technical specifications WW250-500-1000-1500 ../2D

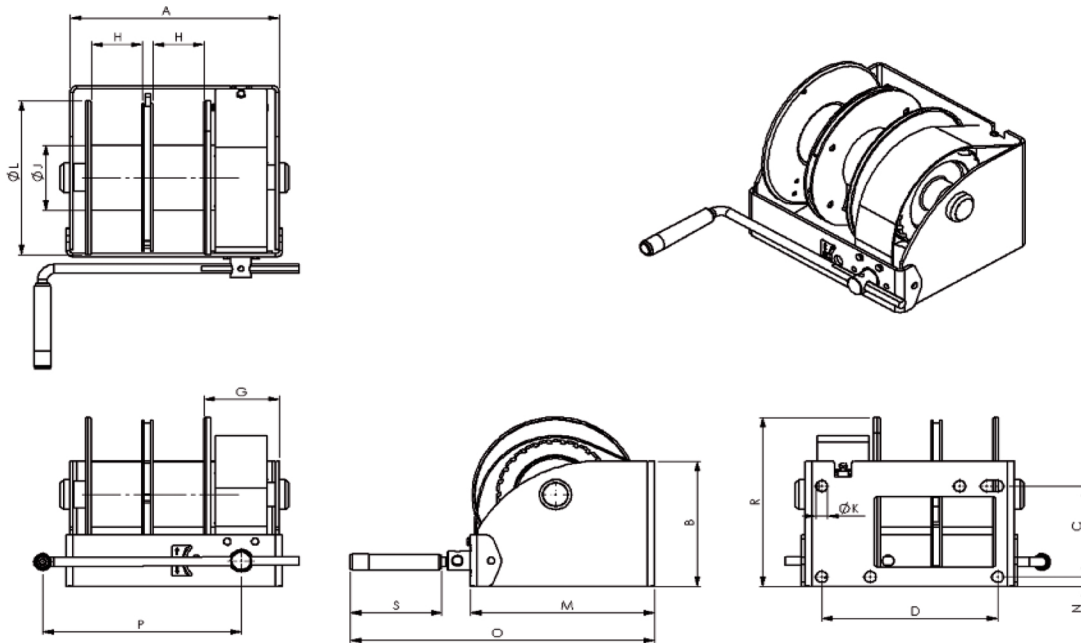

Type	Mounting	Material finish	Remarks
WW250 GR / 2D	Wall, 4x M12 class 8.8	Painted finish	RAL 7035 (grey)
WW250 EV / 2D	Wall, 4x M12 class 8.8	Zinc-plated finish	
WW500 GR / 2D	Wall, 4x M12 class 8.8	Painted finish	RAL 7035 (grey)
WW500 EV / 2D	Wall, 4x M12 class 8.8	Zinc-plated finish	
WW1000 GR / 2D	Wall, 4x M16 class 8.8	Painted finish	RAL 7035 (grey)
WW1000 EV / 2D	Wall, 4x M16 class 8.8	Zinc-plated finish	
WW1500 GR / 2D	Wall, 4x M16 class 8.8	Painted finish	RAL 7035 (grey)
WW1500 EV / 2D	Wall, 4x M16 class 8.8	Zinc-plated finish	

Dimensions (mm)	A	B	C	D	G	H	J	K	L	M	N	O	P	R	S
WW250	238	145	100	192	107	47	48	14	160	191	15	365	280	171	132
WW500	269	160	115	223	108	62	70	14	190	221	15	393	325	193	132
WW1000	302	195	141	254	109	73	102	17	240	266	15	440	350	263	132
WW1500	302	250	178	254	109	73	102	17	240	278	15	451	350	306	132

Technical specifications	WW250	WW500	WW1000	WW1500
Capacity:				
1 st cable layer	2 x 125 kg	2 x 250 kg	2 x 500 kg	2 x 750 kg
Last cable layer	2 x 46 kg	2 x 104 kg	2 x 243 kg	2 x 399 kg
Crankforce 1 st cable position	6 daN	10 daN	13 daN	14 daN
Hoisting length by one rotation of crank , 1 st layer	17 mm	20 mm	13 mm	9 mm
Max. cable storage (one drum compartment)	44 m	84 m	64 m	28 m
Diameter cable (EN 12383-4)	4 mm	4 mm	6 mm	8 mm
Min. breaking load cable	9 kN	9 kN	17 kN	34 kN
Own weight	13,5 kg	16,5 kg	27,5 kg	28,5 kg



Telephone: +44 (0)1482 620991
 Email: sales@winchsystems.co.uk
 Web: www.winchsystems.co.uk