

TL150 ..

Spur gear winch



Hand driven spur gear winch:

- robust and safe hoisting winch
- static safety factor of 4
- load pressure brake with double ratchet system
- maintenance-free bearing
- adjustable crank from 250 to 280 mm, ergonomic plastic grip
- cable outlet upwards, downwards or at rear
- paint thickness is 60 - 80 Micron in 1 layer (in compliance with DIN/ISO 12944, C1M)
- optional ATEX certified Ex II 3 GD T3, suitable for zone 2 and 22
- in compliance with EN 13157 and DIN 15020 and EX types ATEX 114 (94/9/EG)



Telephone: +44 (0)1482 620991
Email: sales@winchsystems.co.uk
Web: www.winchsystems.co.uk

GEBUWIN
metal products

Technical specifications TL150 ..

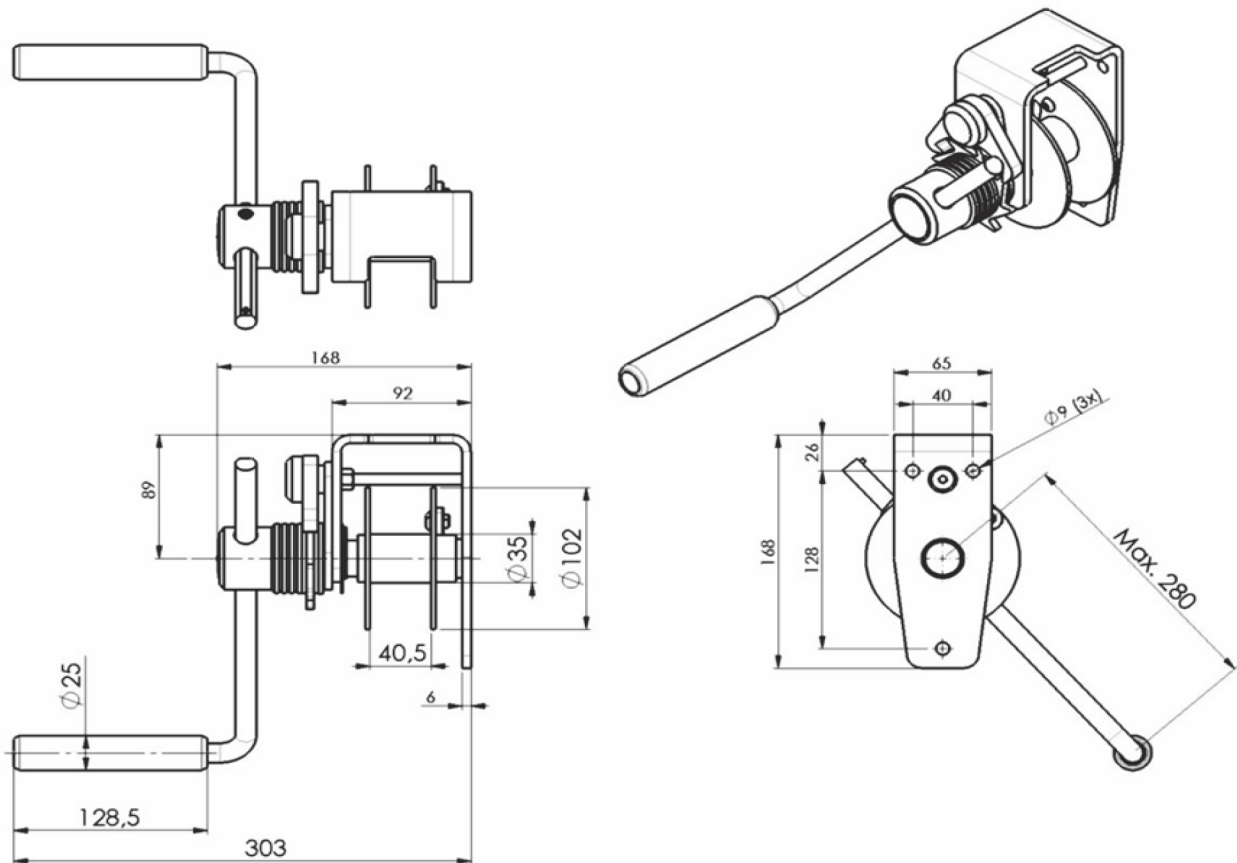

Type	Mounting	Material	Remarks
TL150 GR	Wall, 3x M8 class 8.8	Painted finish	RAL 7035 (grey)
TL150 EV	Wall, 3x M8 class 8.8	Zinc-plated finish	

Technical specifications	TL150
Capacity:	
1 st cable layer	150 kg
Last cable layer	68 kg
Crankforce 1 st cable layer	11 daN
Hoisting length by one rotation of the crank, 1 st layer	122 mm
Cable capacity	13 m
Diameter cable	4 mm
Min. breaking load cable (EN 12383-4)	9 kN
Own weight	4 kg



Telephone: +44 (0)1482 620991
 Email: sales@winchsystems.co.uk
 Web: www.winchsystems.co.uk