

Swivel Davit SD125-250-500

Swivel Davit



Product specification:

- robust and safe lifting davit
- ready to use in 5 seconds
- integrated winch and cable in an ergonomic modern design
- easy to transport
- 360 degrees rotation over a built in ball bearing
- maintenance free
- including 8 meter wire rope (d5 mm) with hook
- adjustable crank
- paint application in compliance with DIN/ISO 12994, C1M - RAL 7035 (grey)
- integrated winch in compliance with EN13157, DIN15020 and EX types ATEX 114 (94/9/EG)
- prices: on request

Options:

- zinc-plated finish (6 - 8 micron) (EV)
- stainless steel grade SAE 316 (SST316)
- ATEX certified  (EX)
 - CE II 3G IIC T3 Ga Tamb <70 °C suitable for zone 2 and 22
 - CE II 3G IIC T200°C Da Tamb <70 °C suitable for zone 2 and 22
- other dimensions on request

Accessories:

- floor, wall and in-cement floor sockets
- carry bag and protection cover



Telephone: +44 (0)1482 620991
Email: sales@winchsystems.co.uk
Web: www.winchsystems.co.uk

GEBUWIN
metal products

Technical specifications SD125-250-500

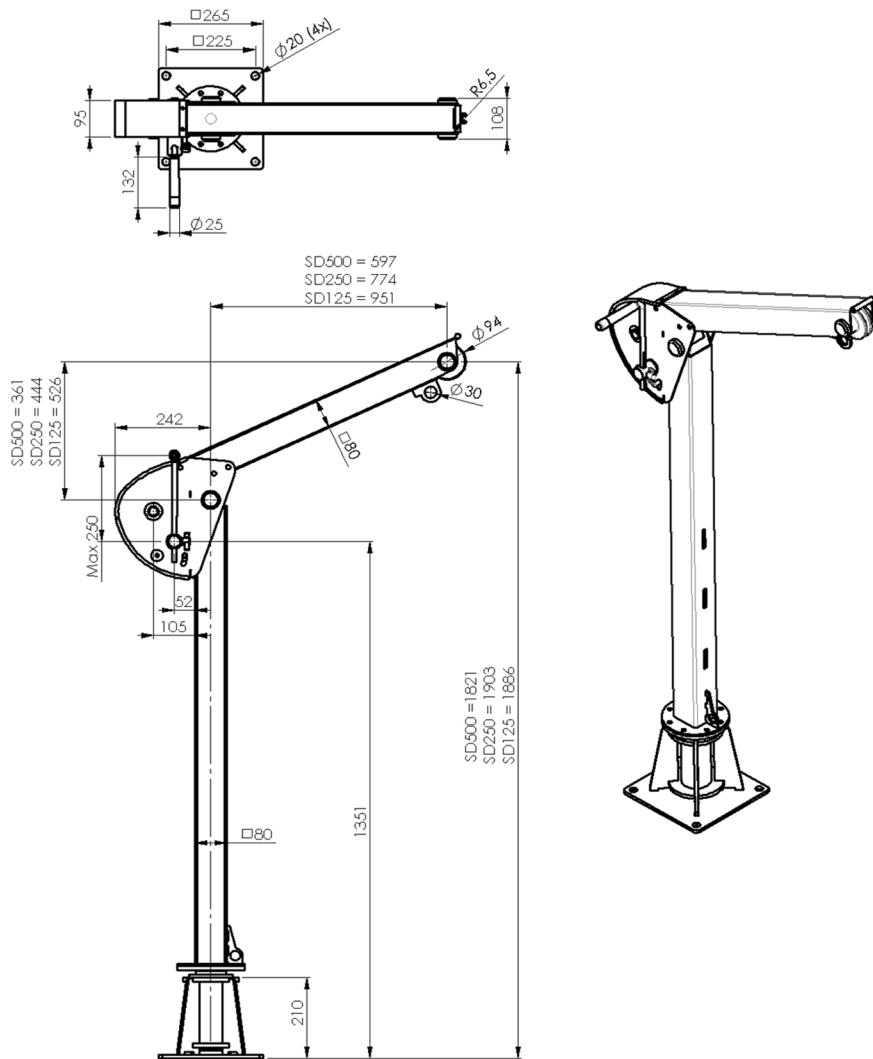

Technical specifications		SD125	SD250	SD500
1st cable layer	kg	125	250	500
Last cable layer (7)	kg	125	250	268
Crankforce 1st cable position	daN	10	10	10
Lifting length one rotation, 1st layer	mm	20	20	20
Max. cable storage last layer *	m	18	18	13
Diameter cable *	mm	4	4	5
Min. breaking load cable	kN	4	7,5	15
Own weight Swivel Davit	kg	30	30	30
Own weight floor-socket	kg	8,9	8,9	8,9
Own weight wall-socket	kg	9	9	9
Own weight in cement-socket	kg	3	3	3
Mounting bolts 4x M* class 8.8		18	18	18

* All models standard delivered with 5 mm wire rope, length 8 m.



Telephone: +44 (0)1482 620991
 Email: sales@winchsystems.co.uk
 Web: www.winchsystems.co.uk