

COMEUP

CWS230

Specification/Part Numbers

- **Lifting capacity:** 230 kg at wire rope top layer
- **Lifting speed:** 9 – 14 m/min
- **Motor rating IP44:**
 - 1 phase, 110V : 1.2 kw x 12 A series wound
 - 1 phase, 220-240V: 1.2 kw x 6 A series wound
- **Gear ratio:** 272:1
- **Maximum lifting height:** 24 m
- **Braking methods:**
 - for motor: Electromagnetic
 - for gear: Double mechanical ratchets
- **Wire rope:** 5 mm x 25 m
- **Drum length:** 60 mm
- **Drum dia.:** 90 mm
- **Drum flange dia.:** 170 mm
- **Net weight, kg:** 15 kg
- **Gross weight :** 26 kg
- **Box dimension, (L x D x H) :** 425 x 365 x 300 mm



Standard Accessories

- Wire rope 5 m x 25 m
- Weight hook CHW-0033
- Remote control, CPB-313
 - * Switch cord 1.25 mm² x 6C x 10 m
 - * Pendant switch CPB-313
- Power lead 1.5 mm x 3C x 5 m and industry plug

Option Accessories

- Remote control, PB-317
 - * Switch cord 1.25 mm² x 6C x 10 m
 - * Pendant switch PB-317 w/an emergency stop button
- Crane CRH-0710 for baby winch ratings 250kg



Telephone: +44 (0)1482 620991
Email: sales@winchsystems.co.uk
Web: www.winchsystems.co.uk

Dimension, mm/in:

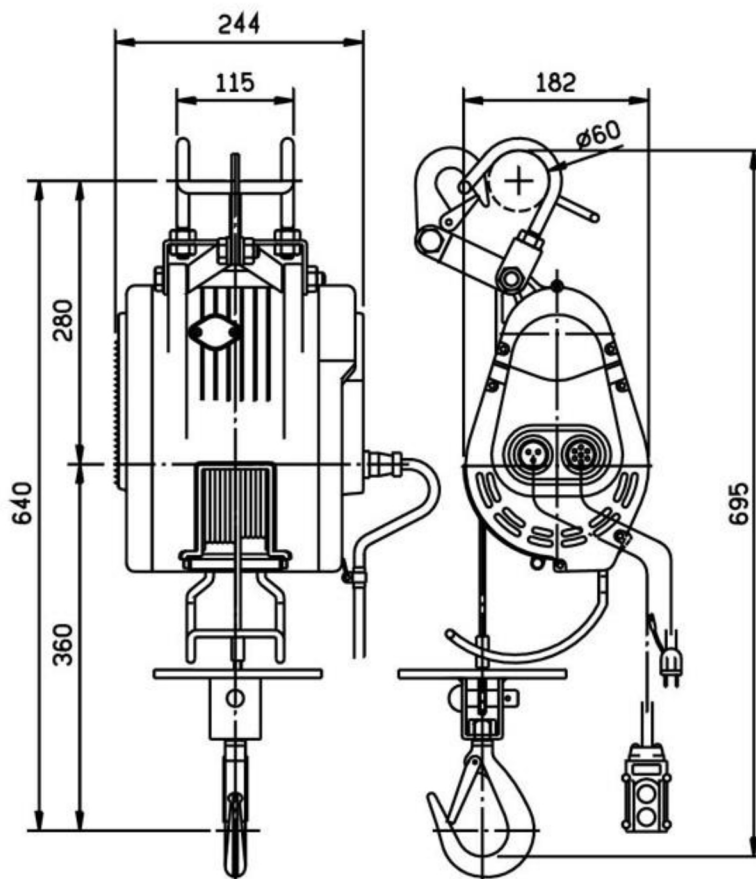

Lifting Capacity, Lifting Speed and Rope Capacity:

Layer of Wire rope	Lifting Capacity, kg	Lifting Speed, m/min	Total Rope on the Drum, m
1 st	351	9	3.3
2 nd	318	10.3	6.9
3 rd	290	11.3	10.9
4 th	267	12.3	15.2
5 th	247	13.3	19.9
6 th	230	14	25

Note: Above performance ratings are based on 50Hz supply.

Warning

The hoist is not intended to be used in any manner for the movement or lifting of personnel. Keep hands, clothing, jewelry, etc. away from wire rope, drum and other moving parts

Warranty

Each new hoist is guaranteed against defects in workmanship and material defects for a period of twelve months from date of purchase.

WIRE ROPES ARE NOT INCLUDED UNDER WARRANTY.



Telephone: +44 (0)1482 620991
Email: sales@winchsystems.co.uk
Web: www.winchsystems.co.uk